

# IAB105V10-1U 5 Inch Rack Extender

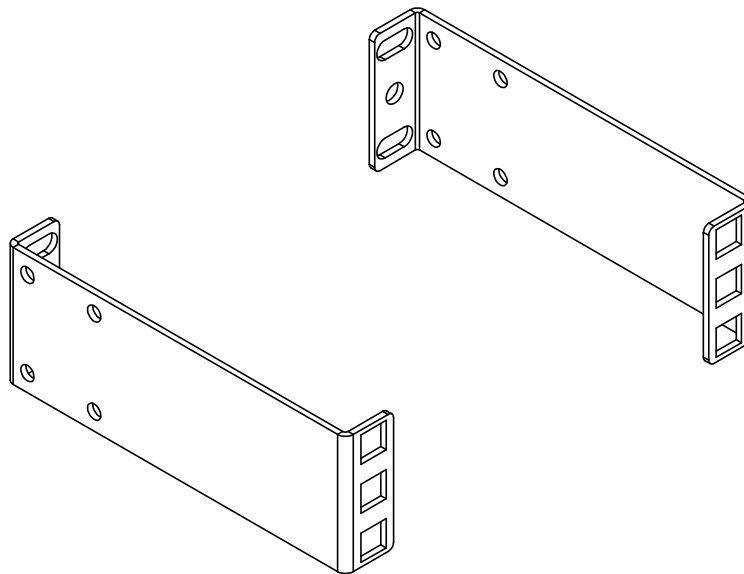

## SPECIFICATION

<b>Model</b>	<b><u><a href="#">IAB105V10-1U</a></u></b>
<b>Length</b>	<b>5 Inch</b>
<b>Rack Size</b>	<b>1U</b>
<b>Thickness</b>	<b>14 Gauge (1.98mm) CRS</b>
<b>Cabinet Side</b>	<b>5.5mm holes and oblong slots. Support #10-32, #12-24 and M6 rack screws</b>
<b>Equipment Side</b>	<b>9.5x9.5mm square cage nut holes. Support #10-32, #12-24 and M6 Cage Nut.</b>
<b>Finish</b>	<b>Black Powder Paint</b>
<b>Max Load Capacity</b>	<b>100 LB Max (4 Post Configuration), 40 Lb Max ( 2 Post Configuration)</b>
<b>Dimension HxWxD</b>	<b>1.75" x 0.170" x 5" (44.45 x 18 x 127mm)</b>
<b>Hardware Included</b>	<b>(8) #10-32 Screw, (4) #12-24 Screw and (4) #10-32 Cage-nuts</b>
<b>Country of Origin</b>	<b>United States (USA)</b>
<b>HTS Code</b>	<b>8302.50.0000.</b>



Industrial Automation and Enclosures Inc

224 N Fehr Way, Bay Shore, NY 11706 e-mail: [sales@iaenclosures.com](mailto:sales@iaenclosures.com) Tel: 516-997-5050 URL: [www.iaenclosures.com](http://www.iaenclosures.com)