

1 2 3 4 5 6 7 8

A  
B  
C  
D  
E

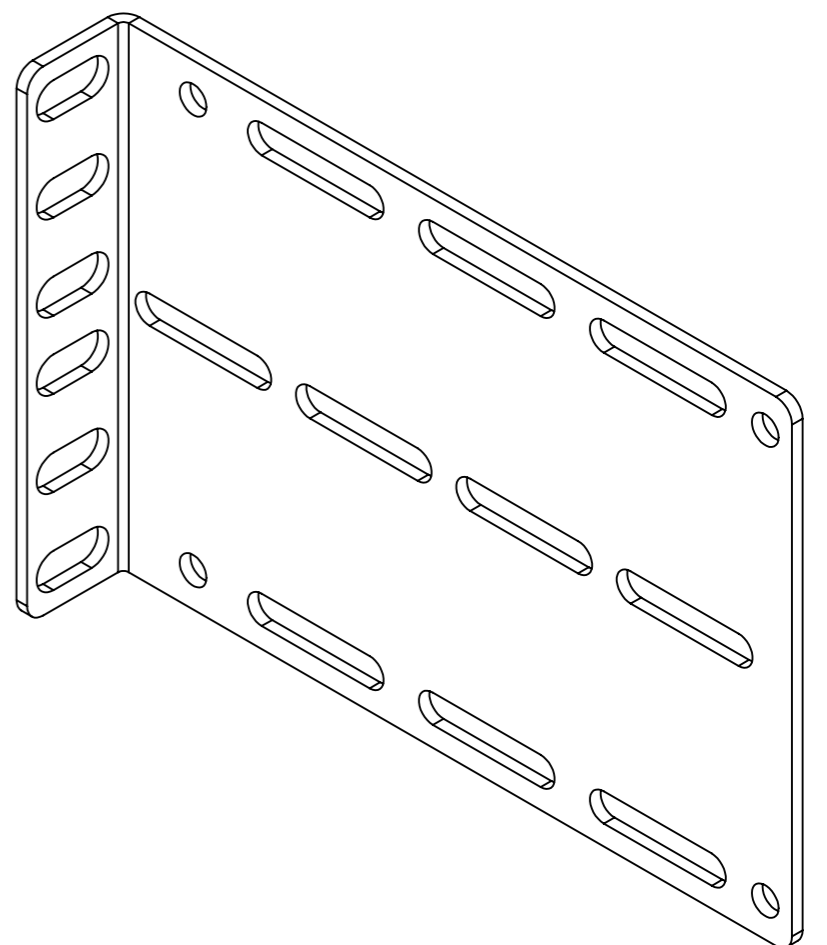
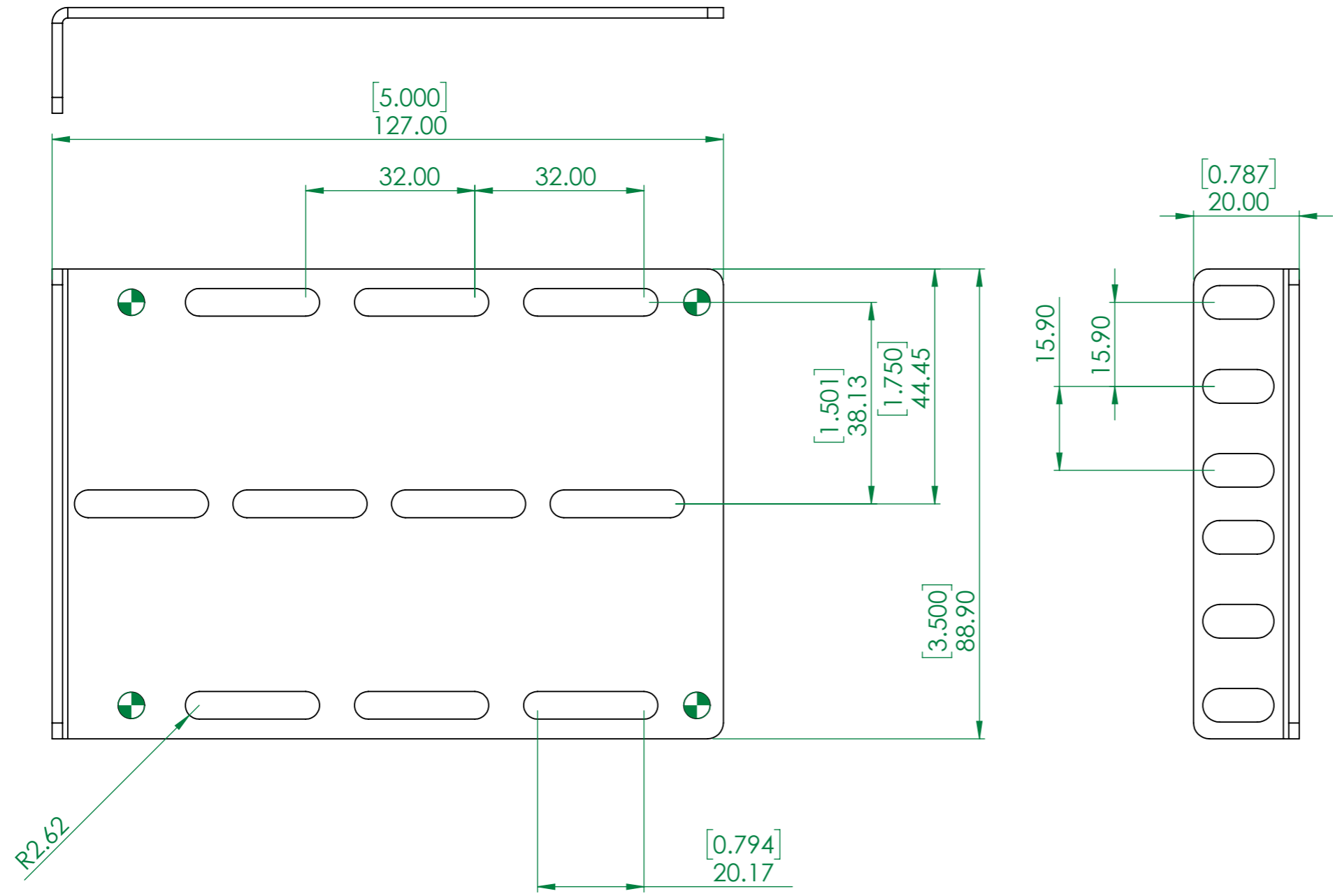

Note:  
 1. No sharp edges.  
 2. RoHS: Manufacturer must ensure that all components used must comply with RoHS Regulation.

<b>Industrial Automation &amp; Enclosures</b> A leading developer of industrial rackmount products TEL:(516)997-5050 FAX:(516)997-5784 ©2016 IAE Inc /www.iaenclosures.com	<b>MODEL</b>	68217	<b>APPV'D</b>		<b>REVISION</b>	V 1.000000	<b>UNSPECIFIED TOLERANCES: ±</b>
	<b>PART NO.</b>	RCB1067S-2	<b>DATE</b>	3/22/2023	<b>FINISH</b>	Black Powder Paint	
	<b>PART NAME</b>	2U L Bracket			<b>SCALE</b>	1:2	<b>SHEET 1 OF 1</b>
					<b>MATERIAL</b>	14 Gauge Steel	<b>UNIT:mm</b>

CONFIDENTIAL DOCUMENT DO NOT COPY