

# Table of Contents

Table of Contents .....	iii
Chapter 1 Introduction.....	1
1.2 Product Description .....	1
1.3 Specifications .....	3
Chapter 2 Installation.....	6
2.1 Board Outline .....	6
2.2 Connectors & Jumpers Location .....	7
2.3 Connectors & Jumpers Summary.....	9
2.4 Pin Assignments & Jumper Settings.....	11
2.5 System Mapping.....	25
2.6 Watchdog Timer .....	28
2.7 GPIO .....	29
2.8 SPI flash.....	30
2.9 PWM .....	31
3.0 IDE to SD .....	32
Chapter 3 Driver Installation.....	33
Appendix .....	34
A. TFT Flat Panel Data Output .....	34
B. TFT Flat Panel Support List.....	35
C. LVDS Flat Panel Support List.....	37
D. Flat Panel Hardware Setting .....	38
E. Flat Panel Wiring and Lighting .....	39
F. TCP/IP library for DOS real mode.....	40
G. BIOS Default Setting.....	41
Warranty.....	42

**This page is blank**

## 1.2 Product Description

The DX86-800 family of low-power x86 embedded controller is designed to meet 3.5" specification, and integrated with the following features.

- 800MHz Vortex86DX System-On-Chip
- VGA, TFT/LVDS LCD support up to 1280x1024 resolution
- 256/ 512MB DDR2 system memory
- Enhanced IDE (UltraDMA-100/66/33)
- 3x 10/100Mbps Ethernet
- 3 USB 2.0 (Host)
- Up to 4 serial ports
- Parallel port
- 16-bit GPIO x1
- Onboard 4MB SPI Flash
- PC/104-Plus expansion bus (Opt.)
- Meet PC/104 stacking spec.
- 2 watchdog timer
- PWM 16~24 channels
- JTAG interface
- AMI BIOS
- Mini-PCI (Type III)
- Single voltage +5V DC
- Support extended operating temperature range of -20°C to +70°C

The DX86-800 3.5" family of embedded controller is designed with backward compatibility in mind, to provide migration path for projects facing end-of-life challenges with their existing x86 based 3.5" controller. The DX86-800 family of controller is designed as a plug in replacement, with backward compatibility to support legacy software to help extend existing product life cycle without heavy re-engineering.

DX86-800 is suitable for broad range of data-acquisition, Industrial automation, Process control, Automotive controller, AVL, Intelligent Vehicle management device, Medical device, Human machine interface, Robotics, machinery control And more...application that required small footprint, low-power and low-cost hardware with open industry standard such as 3.5".

## 1.3 Specifications

Features	
CPU	DM&P SoC CPU Vortex86DX- 800MHz Real Time Clock with Lithium Battery Backup
Cache	L1:16K I-Cache, 16K D-Cache L2:128KB Cache
BIOS	AMI BIOS
Bus Interface	PC/104 Standard Compliant PCI-104 (Optional)
System Memory	256/ 512MB DDR2 Onboard
Watchdog Timer	Software programmable from 30.5 us to 512 seconds x2 sets(Watchdog 1 fully compatible with M6117D)
VGA	XGI Volari Z9s Chipset VGA and TFT Flat Panel Interface Support LVDS Flat Panel Interface Support Onboard 32MB VGA Memory Support resolution up to 1280 x 1024,16MB colors
LAN	Integrated 10/100M Ethernet Realtek 8100B 10/100Mbps Ethernet Controller Half/Full duplex capability
Audio	CM119 USB Audio Controller
I/O Interface	<ul style="list-style-type: none"> <li>● Enhanced IDE port (UltraDMA-100/66/33) x1</li> <li>● RS-232 port x3</li> <li>● RS-232/422/485 port x1 (RS-485:Auto Direction)</li> <li>● Parallel port x1</li> <li>● USB port x3 (USB 2.0 version)</li> <li>● 16-bit GPIO port x1</li> <li>● 10/100Mbps Ethernet port x3</li> </ul>

Connectors	<ul style="list-style-type: none"> <li>● 2.00 mm Ø 44-pin box header for IDE x1</li> <li>● 2.00 mm Ø 44-pin box header for LCD x 1</li> <li>● 2.00 mm Ø 26-pin box header for Printer x1</li> <li>● 2.00 mm Ø 20-pin box header for 16-bit GPIO x1</li> <li>● 2.00 mm Ø 16-pin header for LVDS x 1</li> <li>● 2.00 mm Ø 10-pin box header for RS-232 x3</li> <li>● 2.00 mm Ø 10-pin box header for USB x1</li> <li>● 2.00 mm Ø 8-pin header for Ethernet x 2</li> <li>● 2.54 mm Ø 4-pin header for DC-in x1</li> <li>● 2.54 mm Ø 3-pin header for RS-485 x1</li> <li>● 2.54 mm Ø 2-pin header for Reset x1</li> <li>● 1.25 mm Ø 6-pin wafer for JTAG x1</li> <li>● 0.8mm Ø 124-pin MiNi PCI connector x1</li> <li>● External 15-pin D-Sub female connector for VGA x1</li> <li>● External 9-pin D-Sub male connector for RS-232 x1</li> <li>● External RJ-45 connector for Ethernet x1</li> <li>● External USB connector for x1</li> <li>● External Mini DIN socket for Keyboard/Mouse x1</li> <li>● Type I/II Compact Flash slot x1</li> </ul>
Flash Disk Support	<ul style="list-style-type: none"> <li>● Onboard 4MB SPI Flash Disk (Driver: A)</li> <li>● 44-pin IDE Flash Disk( EmbedDisk 16MB or above)</li> <li>● Type I/II CF Card</li> <li>● 44-pin IDE to Micro SD (Optional)</li> </ul>
PWM	16~24 Channels
SRAM support	512KB (Optional)
Power Requirement	Single Voltage +5V @ 880mA
Dimension	102 X 144mm (4.01 x 5.67 inches)
Weight	150g
Operating Temperature	-20°C ~ +70°C -40°C ~ +85°C (Optional)

# Chapter 2

## Installation

### 2.1 Board Outline

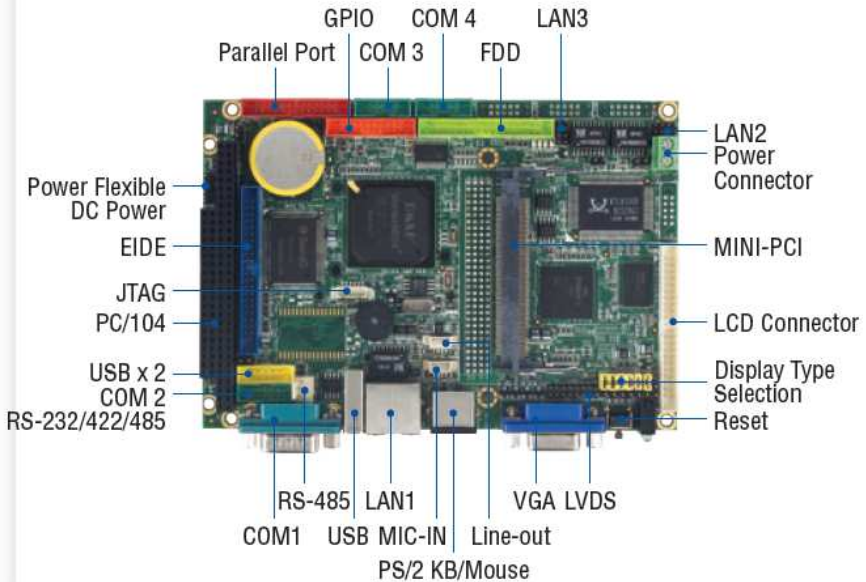

(Note1: COM2 RS232/422/485 is selected by BIOS setting)

(Note2: J39 Default setting of JTAG Has to be Disable: Pin 1 & Pin 2 short)

## 2.2 Connectors & Jumpers Location

### Connectors

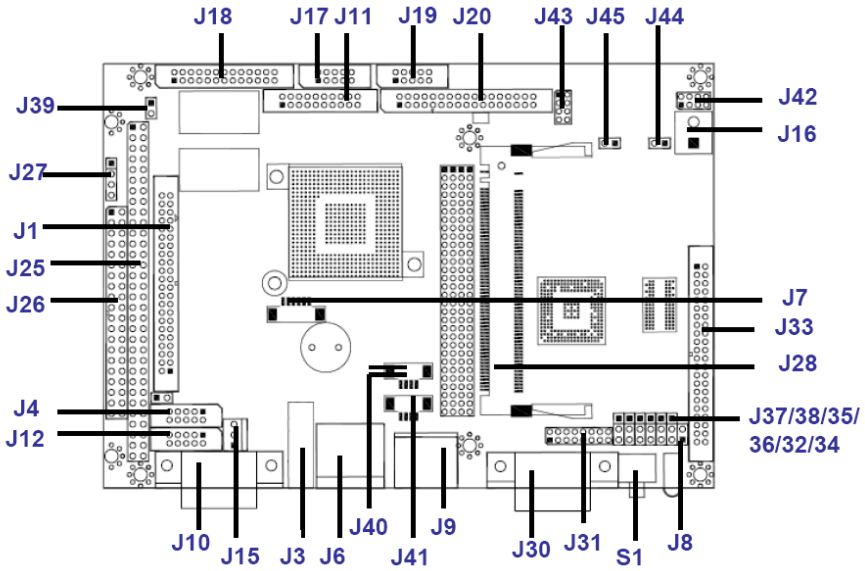

# Jumpers & LEDs

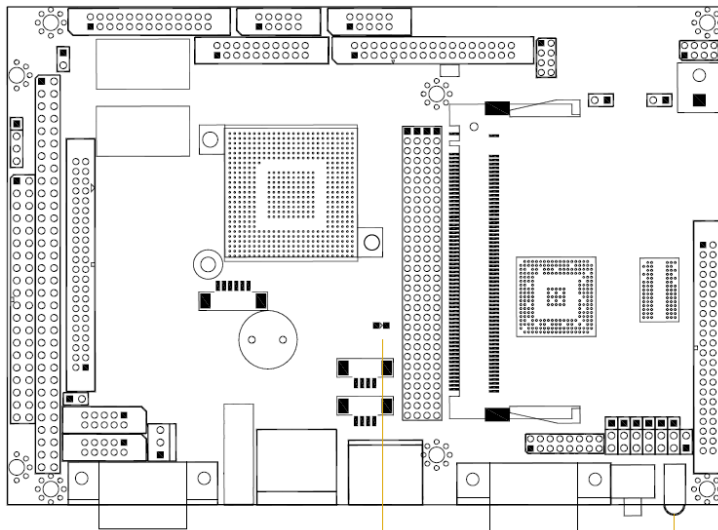

MTBF\_LED

Above: Power\_LED

Under: IDE\_LED



## 2.3 Connectors & Jumpers Summary

Summary Table

Nbr	Description	Type of Connections	Pin nbrs.
J1	IDE	Box Header, 2.0Ø ,22x2	44-pin
J2	CF Card Master/Slave Select	Pin Header, 2.54Ø , 2x1	2-pin
J3	USB 2	USB connector	4-pin
J4	USB 1	Box Header,2.0Ø , 5x2	10-pin
J6	10/100Base-T Ethernet LAN	RJ45 Connector	8-pin
J7	JTAG	Wafer, 1.25Ø , 6x1	6-pin
J8	Reset	Pin Header, 2.54Ø,1x2	2-pin
J9	PS/2 Keyboard / Mouse	Mini-DIN Female	6-pin
J10	COM1	D-Sub Male	9-pin
J11	GPIO ( Port 0 / 1 /PWMx16)	Box Header, 2.0Ø ,10x2	20-pin
J12	COM2(RS232/RS485/RS422)	Box Header, 2.54Ø 5x2	10-pin
J15	RS-485	Molex Header,2.54Ø, 3x1	3-pin
J16	Power Connector	Terminal Block 5.0Ø,2x1	2-pin
J17	COM3	Box Header, 2.0Ø 5x2	10-pin
J18	PRINT	Box Header, 2.0Ø , 13x2	26-pin
J19	COM4	Box Header, 2.0Ø 5x2	10-pin
J25	PC104 Connector – 64 pin	Box Header, 2.54Ø 32x2	64-pin
J26	PC104 Connector – 40 pin	Box Header, 2.54Ø 20x2	40-pin
J27	4P Power Source (Interconnect to PC/104 – J25)	Pin Header, 2.54Ø , 4x1	4-pin
J28	MINI_PCI_Type- III	Type- III connector	124-pin
J29	PC/104 + (Optional)	Box Header, 2.0Ø , 30x4	120-pin
J30	VGA	D-Sub Female	15-pin
J31	LVDS	Pin Header, 2.0Ø 8x2	16-pin
J32	Display type Setup	Pin Header, 2.54Ø , 3x1	3-pin
J38			
J33	LCD	Box Header,2.0Ø ,22x2	44-pin
J39	JTAG Disable (Default setting)	Pin Header, 2.54Ø,1x2	2-pin
J40	LINE-OUT	Wafer, 1.25Ø , 4x1	4-pin
J41	MIC-IN	Wafer, 1.25Ø , 4x1	4-pin

<b>J44</b>	LAN2 Enable/Disable	Pin Header, 2.54Ø, 2x1	2-pin
<b>J45</b>	LAN3 Enable/Disable	Pin Header, 2.54Ø, 2x1	2-pin
<b>CF1</b>	Compact Flash	Type I/II CF Connector	50-pin
<b>PWR_LED</b>	POWER Active LED (Red)		
<b>IDE_LED</b>	IDE Active LED (Green )		
<b>MTBF-LED</b>	MTBF-Out (Orange)	LED-SMD	
<b>SP1</b>	BUZZER		
<b>S1</b>	RESET SWITCH		

## 2.4 Pin Assignments & Jumper Settings

### J1: IDE (44 Pins)

Pin #	Signal Name	Pin #	Signal Name
1	IDERST	2	GND
3	IDED7	4	IDED8
5	IDED6	6	IDED9
7	IDED5	8	IDED10
9	IDED4	10	IDED11
11	IDED3	12	IDED12
13	IDED2	14	IDED13
15	IDED1	16	IDED14
17	IDED0	18	IDED15
19	GND	20	NC
21	IDEREQ	22	GND
23	IDEIOW	24	GND
25	IDEIOR	26	GND
27	ICHRDY	28	GND
29	IDEACK	30	GND
31	IDEINT	32	NC
33	IDESA1	34	IDECBLID
35	IDESA0	36	IDESA2
37	IDECS-0	38	IDECS1
39	IDELED	40	GND
41	VCC	42	VCC
43	GND	44	NC

### J2: CF Card Master / Slave Select

Pin #	Signal Name
CLOSE	Master
OPEN	Slave

## J4: USB 1

Pin #	Signal Name	Pin #	Signal Name
1	VCC	2	VCC
3	LUSBD0-	4	LUSBD1-
5	LUSBD0+	6	LUSBD1+
7	GND	8	GND
9	GGND	10	GGND

## J6: LAN1

Pin #	Signal Name	Pin #	Signal Name
1	TD+	2	TD-
3	RO+	4	NC
5	NC	6	RO-
7	NC	8	NC

## J7: JTAG

Pin #	Signal Name	Pin #	Signal Name
1	VCC	2	GND
3	TCK	4	TDO
5	TDI	6	TMS

## J8: RESET

Pin #	Signal Name	Pin #	Signal Name
1	Reset	2	GND

## J9: PS/2 KBD / Mouse

Pin #	Signal Name	Pin #	Signal Name
1	KBCLK	2	MSCLK
3	GND	4	KBDAT
5	MSDAT	6	VCC
7	GGND	8	GGND
9	GGND		

### J10: COM1 (Optional: TTL / GPIO-P4 / PWMx8)

Pin #	Signal Name	Pin #	Signal Name
1	DCD1	2	RXD1
3	TXD1	4	DTR1
5	GND	6	DSR1
7	RTS1	8	CTS1
9	RI1	10	GND
11	GND		

### J11: GPIO (Port 0 / Port 1 / PWMx16)

Pin #	Signal Name	Pin #	Signal Name
1	GND	2	VCC
3	GP00	4	GP10
5	GP01	6	GP11
7	GP02	8	GP12
9	GP03	10	GP13
11	GP04	12	GP14
13	GP05	14	GP15
15	GP06	16	GP16
17	GP07	18	GP17
19	VCC	20	GND

### J12: COM2 RS232 / RS422 / RS485 (Optional: TTL)

Pin #	Signal Name	Pin #	Signal Name
1	DCD2/422TX-/RS485-	2	RXD2/422TX+/RS485+
3	TXD2 / 422RX+	4	DTR2 / 422RX-
5	GND	6	DSR2
7	RTS2	8	CTS2
9	RI2	10	NC

### J15: RS485 (Auto direction)

Pin #	Signal Name
1	RS485+
2	RS485-
3	GND

### J16: Power Connector (Terminal Block 5.0mm)

Pin #	Signal Name
1	+5V
2	GND

### J17: COM3 (Optional: TTL)

Pin #	Signal Name	Pin #	Signal Name
1	DCD3	2	RXD3
3	TXD3	4	DTR3
5	GND	6	DSR3
7	RTS3	8	CTS3
9	RI3	10	NC

### J18: PRINT

Pin #	Signal Name	Pin #	Signal Name
1	STB-	14	AFD-
2	PD0	15	ERR-
3	PD1	16	INIT-
4	PD2	17	SLIN-
5	PD3	18	GND
6	PD4	19	GND
7	PD5	20	GND
8	PD6	21	GND
9	PD7	22	GND
10	ACK-	23	GND
11	BUSY	24	GND
12	PE	25	GND
13	SLCT	26	NC

## J19: COM4 (Optional: TTL)

Pin #	Signal Name	Pin #	Signal Name
1	DCD4	2	RXD4
3	TXD4	4	DTR4
5	GND	6	DSR4
7	RTS4	8	CTS4
9	RI4	10	NC

## J20: FDD

Pin #	Signal Name	Pin #	Signal Name
1	GND	2	DENSEL
3	GND	4	NC
5	GND	6	NC
7	GND	8	INDEX\
9	GND	10	MTRO\
11	GND	12	DS1\
13	GND	14	DS0\
15	GND	16	MTR1\
17	GND	18	DIR\
19	GND	20	STEP\
21	GND	22	WD\
23	GND	24	WG\
25	GND	26	TR0\
27	GND	28	WP\
29	GND	30	RD\
31	GND	32	HDSEL\
33	GND	34	DSKCHG\

## J25: PC104 Connector – 64pin

Pin #	Signal Name	Pin #	Signal Name
1	IOCHCHK*	2	GND
3	SD7	4	RESETDRV
5	SD6	6	VCC
7	SD5	8	IRQ9
9	SD4	10	-5V
11	SD3	12	DRQ2
13	SD2	14	-12V
15	SD1	16	OVS
17	SD0	18	+12V
19	IOCHRDY	20	GND
21	AEN	22	SMEMW *
23	SA19	24	SMEMR *
25	SA18	26	IOW *
27	SA17	28	IOR *
29	SA16	30	DACK3 *
31	SA15	32	DRQ3
33	SA14	34	DACK1 *
35	SA13	36	DRQ1
37	SA12	38	REFRESH*
39	SA11	40	SYSCLK
41	SA10	42	IRQ7
43	SA9	44	IRQ6
45	SA8	46	IRQ5
47	SA7	48	IRQ4
49	SA6	50	IRQ3
51	SA5	52	DACK2 *
53	SA4	54	TC
55	SA3	56	BALE
57	SA2	58	VCC
59	SA1	60	OSC
61	SA0	62	GND
63	GND	64	GND



## J26: PC104 Connector – 40pin

Pin #	Signal Name	Pin #	Signal Name
1	GND	2	GND
3	MEMCS16*	4	SBHE *
5	IOCS16 *	6	SA23
7	IRQ10	8	SA22
9	IRQ11	10	SA21
11	IRQ12	12	SA20
13	IRQ15	14	SA19
15	IRQ14	16	SA18
17	DACK0 *	18	SA17
19	DRQ0	20	MEMR *
21	DACK5 *	22	MEMW *
23	DRQ5	24	SD8
25	DACK6 *	26	SD9
27	DRQ6	28	SD10
29	DACK7 *	30	SD11
31	DRQ7	32	SD12
33	VCC	34	SD13
35	MASTER *	36	SD14
37	GND	38	SD15
39	GND	40	NC

## J27: 4P Power Source (Interconnect to PC/104 – J25)

Pin #	Signal Name
1	-5V
2	-12V
3	+12V
4	GND

## J29: PC/104 + (Optional)

VI/O Default setting: +5V

If you need to use VI/O as +3.3V, please see the page 19.

Pin #	A	B	C	D
1	GND	NC	+5V	AD00
2	VI/O(+5V)	AD02	AD01	+5V
3	AD05	GND	AD04	AD03
4	C/BE0#	AD07	GND	AD06
5	GND	AD09	AD08	GND
6	AD11	VI/O(+5V)	AD10	GND
7	AD14	AD13	GND	AD12
8	+3.3V	C/BE1#	AD15	+3.3V
9	SERR#	GND	NC	PAR
10	GND	PERR#	+3.3V	NC
11	STOP#	+3.3V	LOCK#	GND
12	+3.3V	TRDY#	GND	DEVSEL#
13	FRAME#	GND	IRDY#	+3.3V
14	GND	AD16	+3.3V	C/BE2#
15	AD18	+3.3V	AD17	GND
16	AD21	AD20	GND	AD19
17	+3.3V	AD23	AD22	+3.3V
18	IDSEL0	GND	IDSEL1	IDSEL2
19	AD24	C/BE3#	VI/O(+5V)	IDSEL3
20	GND	AD26	AD25	GND
21	AD29	+5V	AD28	AD27
22	+5V	AD30	GND	AD31
23	REQ0#	GND	REQ1#	VI/O(+5V)
24	GND	REQ2#	+5V	GNT0#
25	GNT1#	VI/O(+5V)	GNT2#	GND
26	+5V	CLK0	GND	CLK1
27	CLK2	+5V	CLK3	GND
28	GND	INTD#	+5V	RST#
29	+12V	INTA#	INTB#	INTC#
30	-12V	NC	NC	GND

Please remove the 0 ohm (1206 type) of R260 and add 0 ohm (1206 type) on R261

PCI-104 VIO pin 從 5V 跳至 3.3V :  
將R260 拆下焊至 R261

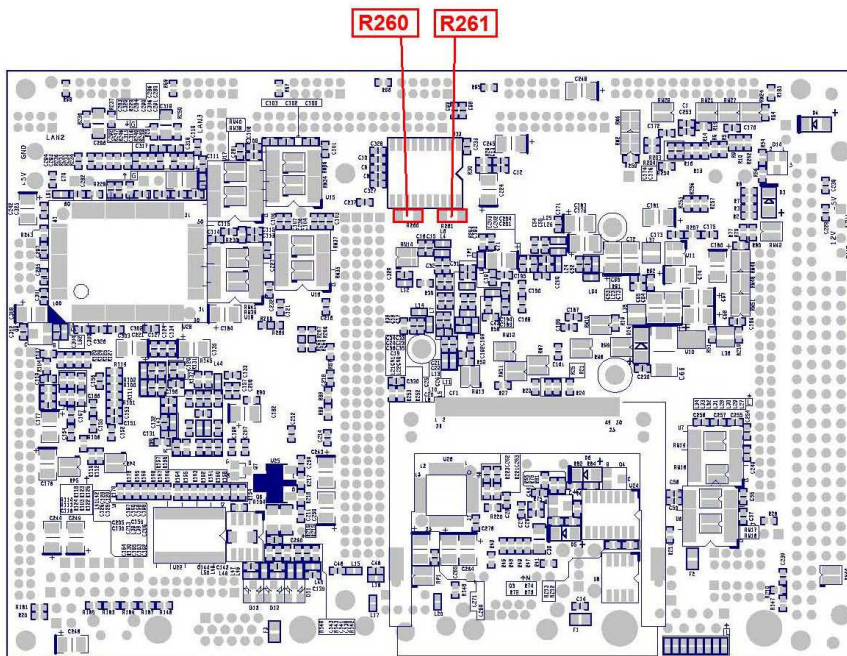

### J30: VGA

Pin #	Signal Name	Pin #	Signal Name
1	R OUT	2	G OUT
3	B OUT	4	NC
5	GND	6	GND
7	GND	8	GND
9	VCC	10	GND
11	NC	12	DDCDAT
13	HSYNC	14	VSYNC
15	DDCCLK		

### J31: LVDS

Pin #	Signal Name	Pin #	Signal Name
1	VCC3 (3.3V)	2	VCC3 (3.3V)
3	GND	4	GND
5	RxIN0+	6	RxIN0-
7	RxIN1-	8	GND
9	GND	10	RxIN1+
11	RxIN2+	12	RxIN2-
13	CKIN-	14	GND
15	GND	16	CKIN+

## J32~J38: Display type setup (CRT /LCD)

Connector	Pin #	Signal Name
J32	1	VCC
	2	GPIOA
	3	GND
J34	1	VCC
	2	GPIOB
	3	GND
J35	1	VCC
	2	GPIOC
	3	GND
J36	1	VCC
	2	GPIOD
	3	GND
J37	1	VCC
	2	GPIOE
	3	GND
J38	1	VCC
	2	GPIOF
	3	GND

[\(Please refer to Appendix D, for Display type setup\)](#)

### J33: LCD (DVO) Connector

Pin #	Signal Name	Pin #	Signal Name
1	+3.3V	2	+3.3V
3	LG2	4	LG3
5	LG4	6	LG5
7	NC	8	NC
9	LR0	10	LR1
11	LR2	12	LR3
13	LR4	14	LR5
15	GND	16	NC
17	NC	18	NC
19	NC	20	GND
21	NC	22	NC
23	LB0	24	LB1
25	LB2	26	LB3
27	LB4	28	LB5
29	NC	30	NC
31	LG0	32	LG1
33	GND	34	GND
35	NC	36	LCLK
37	NC	38	LDE
39	NC	40	LHSYNC
41	NC	42	LVSYNC
43	LBACKL	44	LVDDEN

[\(Please refer to Appendix A, for TFT Flat Panel Data Output\)](#)

### J39: JTAG Disable (Default setting: Pin 1 & Pin 2 short)

Pin #	Signal Name	Pin #	Signal Name
1	GND	2	JTAG Disable

## J40: LINE OUT

Pin #	Signal Name
1	LOUTR
2	GND
3	GND
4	LOUTL

## J41: MIC-IN

Pin #	Signal Name
1	MICVREF
2	GND
3	GND
4	MIC-IN

## J42: LAN2

Pin #	Signal Name	Pin #	Signal Name
1	TX+1	2	TX-1
3	RX+1	4	LED01
5	LED01+	6	RX-1
7	LED11+	8	LED11

## J43: LAN3

Pin #	Signal Name	Pin #	Signal Name
1	TX+2	2	TX-2
3	RX+2	4	LED02
5	LED02+	6	RX-2
7	LED12+	8	LED12

## J44: LAN2 Enable/Disable

Pin #	Signal Name
CLOSE	LAN Off
OPEN	LAN ON

## J45: LAN3 Enable/Disable

Pin #	Signal Name
CLOSE	LAN Off
OPEN	LAN ON



## 2.5 System Mapping

### System Mapping

#### Memory Mapping

Address	Description	Usage
0000:0000-9000:FFFF	System RAM	*
A000:0000-A000:FFFF	EGA/VGA Video Memory	*
B000:0000-B000:7FFF	MDA RAM, Hercules graphics display RAM	*
B000:8000-B000:FFFF	CGA display RAM	*
C000:0000-C000:7FFF	EGA/VGA BIOS ROM	*
C000:8000-C000:FFFF	Boot ROM enable.	*
D000:0000-D700:FFFF	Expansion ROM space.	
D800:0000-DB00:FFFF	SPI FLASH Emulation Floppy A Enable.	
DC00:0000-DF00:FFFF	Expansion ROM space.	
E000:0000-E000:FFFF	USB Legacy SCSI ROM space.	*
F000:0000-F000:FFFF	Motherboard BIOS	*

#### I/O Mapping

I/O Address	Owner	Usage
0000h - 000Fh	DMA 8237-1	*
0010h - 0017h	COM 9	
0018h - 001Fh	Empty	
0020h - 0021h	PIC 8259-1	*
0022h - 0023h	6117D configuration port	*
0024h - 002Dh	Empty	
002Eh - 002Fh	Forward to LPC BUS	*
0030h - 003Fh	Empty	
0040h - 0043h	Timer counter 8254	*
0044h - 0047h	Empty	
0048h - 004Bh	PWM counter 8254	*
004Ch - 004Dh	Empty	
004Eh - 004Fh	Forward to LPC BUS	*
0050h - 005Fh	Empty	
0060h	Keyboard data port	*
0061h	Port B + NMI control port	*
0062h - 0063h	8051 download 4K address counter	*

0064h	Keyboard status port	*
0065h	WatchDog0 reload counter	*
0066h	8051 download 8bit data port	*
0067h	WatchDog1 reload counter	*
0068h - 006Dh	WatchDog1 control register	*
006Eh - 006Fh	Empty	
0070h - 0071h	CMOS RAM port	*
0072h - 0075h	MTBF counter	*
0076h - 0077h	Empty	
0078h - 007Ch	GPIO port 0,1,2,3,4 default setup	*
007Dh - 007Fh	Empty	
0080h - 008Fh	DMA page register	*
0090h - 0091h	Empty	
0092h	System control register	*
0093h - 0097h	Empty	
0098h - 009Ch	GPIO direction control	*
00A0h - 00A1h	PIC 8259-2	*
00A2h - 00BFh	Empty	
00C0h - 00DFh	DMA 8237-2	*
00E0h - 00FFh	Empty	
0100h - 0101h	GPCS1 default setting address	*
0170h - 0177h	IDE1 (IRQ 15)	
01F0h - 01F7h	IDE0 (IRQ 14)	*
0220h - 0227h	COM8 Forward to LPC BUS	
0228h - 022Fh	COM7 Forward to LPC BUS	
0238h - 023Fh	COM6 Forward to LPC BUS	
0278h - 027Fh	Printer port (IRQ 7, DMA 0)	*
02E8h - 02EFh	COM4 (IRQ 11)	*
02F8h - 02FFh	COM2 (IRQ 3)	*
0338h - 033Fh	COM5 Forward to LPC BUS	
0376h	IDE1 ATAPI device control write only register	*
03E8h - 03EFh	COM3 (IRQ 10)	*
03F0h - 03F7h	Floppy Disk (IRQ 6, DMA 2)	*
03F6h	IDE0 ATAPI device control write only register	*
03F8h - 03FFh	COM1 (IRQ 4)	*
0480h - 048Fh	DMA High page register	*
0490h - 0499h	Instruction counter register	*
04D0h - 04D1h	8259 Edge,/ level control register	*
0CF8h - 0CFFh	PCI configuration port	*
D400h - D4FFh	on board LAN	*
FC00h - FC05h	SPI Flash BIOS control register	*

FC08h - FC0Dh	External SPI BUS control register ( output pin configurable GPIO3[0-3] )	*
---------------	--------------------------------------------------------------------------	---

## IRQ Mapping

IRQ#	Description	Usage
IRQ0	System Timer	*
IRQ1	Keyboard Controller	*
IRQ2	Cascade for IRQ8 - 15	
IRQ3	Serial Port 2	*
IRQ4	Serial Port 1	*
IRQ5	USB	*
IRQ6	Floppy	*
IRQ7	Parallel Port	*
IRQ8	Real Time Clock	*
IRQ9	USB / RTL8100B LAN1 / RTL8100B LAN2 / Ethernet 10/100M LAN	*
IRQ10	Serial Port 3	*
IRQ11	Serial Port 4	*
IRQ12	Mouse	*
IRQ13	Math Coprocessor	*
IRQ14	Hard Disk Controller#1	*
IRQ15	USB	*

## DMA Mapping

DMA#	Description	Usage
DMA0		
DMA1		
DMA2	Floppy Disk Controller	*
DMA3		
DMA5		
DMA6		
DMA7		

## 2.6 Watchdog Timer

There are two watchdog timers in Vortex86SX/DX CPU. One is compatible with M6117D watchdog timer and the other is new. The M6117D compatible watchdog timer is called WDT0 and new one is called WDT1.

## **2.7 GPIO (General Purpose Input / Output)**

40 GPIO pins are provided by the Vortex86SX/DX for general usage in the system. All GPIO pins are independent and can be configured as inputs or outputs, with or without pull-up/pull-down resistors.

## **2.8 SPI flash (Serial Peripheral Interface)**

As SPI Flash (Serial Peripheral Interface) offers many benefits including: reduced controller pin count, smaller and simpler PCBs, reduced switching noise, less power consumption, and lower system cost

Many of users may consider using a formatted SPI flash to boot for the system or emulate SPI flash as Floppy (A: Driver or B: Driver). Then you must know how to set for this condition in CMOS Setup and boot up under DOS 6.22, X-DOS, DR-DOS and Free DOS.

## **2.9 PWM (Pulse-width modulation)**

Pulse-width modulation (PWM) of a signal or power source involves the modulation of its duty cycle, to either convey information over a communications channel or control the amount of power sent to a load.

The popular applications of pulse width modulation are in speed control of electric motors, volume control of Class D audio amplifiers or brightness control of light sources and many other power electronics applications.

The Vortex86DX SoC integrated 32 channels of PWM interface enabling the Automation, robotic industry to a New Age x86 SoC platform and we also offer the sample code of PWM which will guide the engineer to control the PWM functionality smoothly.

# Chapter 3

## Driver Installation

### VGA

The Vortex86DX processor also use external Display chip “Volari™ Z9s” which is an ultra low powered graphics chipset with total power consumption at around 1-1.5 W. It is capable in providing VGA display output upto 1600x1200. With DVO interface, developers could easily connect flat Panel to support TFT and LVDS output.

### LAN

The Vortex86DX processor also integrated 10/100Mbps Ethernet controller that supports both 10/100BASE-T and allows direct connection to your 10/100Mbps Ethernet based Local Area Network for full interaction with local servers, wide area networks such as the Internet.

The controller supports: Half / Full-Duplex Ethernet function to double channel bandwidth, auto media detection.

### AUDIO

CM119 is a highly integrated single chip USB audio controller specifically for VoIP (Voice over internet protocol) application. All essential analog modules are embedded in CM119, including dual DAC and earphone driver, ADC, microphone booster, PLL, regulator, and USB transceiver. 8 GPIO pins can constitute a 24 key matrix directly support keypad control function without MCU.

Many features are programmable with jumper pins or external EEPROM. Vender can customize unique USB VID/PID to EEPROM for VoIP software authentication. Moreover, individual unique phone number for each device is possible via serial number stored in external EEPROM.

### Operating system support

The DX86-800 CPU board supports Embedded software: Free DOS, DOS 6.22, PCDOS 7.1, DR-DOS,x-DOS,OS/2,Windows CE 6.0, Windows 98, Windows XP Professional, Windows Embedded standard (XPE) and Windows 2000 (SP4)



# Appendix

## A. TFT Flat Panel Data Output

Vortex86 SX/DX Pin Name	TFT LCD 18 / 24 Bits
1	VCC3 (3.3V)
2	VCC3 (3.3V)
3	LG2
4	LG3
5	LG4
6	LG5
7	NC
8	NC
9	LR0
10	LR1
11	LR2
12	LR3
13	LR4
14	LR5
15	GND
16	NC
17	NC
18	NC
19	NC
20	GND
21	NC
22	NC
23	LB0
24	LB1
25	LB2
26	LB3
27	LB4
28	LB5
29	NC
30	NC
31	LG0
32	LG1
33	GND
34	GND
35	NC
36	LCLK
37	NC
38	LDE
39	NC
40	LHSYNC
41	NC
42	LVSYNC
43	LBACKL
44	LVDDEN

## B.TFT Flat Panel Support List

Size	Brand	Resolution	Model No.
5.7"	Data image	320x240	FG050701DSSWBG01
5.7"	Optrex	320x240	55264GD057J-FW-ABN
5.7"	TOSHIBA	320x240	LTA057A343F
5.7"	Sharp	320x240 (QVGA / VGA)	LQ057Q3DC02
5.7"	Kyocera	320x240 (QVGA / VGA)	TCG057QV1AC-G10
5.7"	PVI	320x240 (QVGA / VGA)	PD057VU4 /U5
5.7"	Data image	640x480	FG050710DSSWJG01/DG01
5.7"	Ampire	640x480	AM-640480GTMQW-T00H
5.7"	URT	640x480	UMSH-8004MD-T
5.7"	Sharp	640x480	LQ057V3DG01
5.7"	CPT	640x480	CLAA057VA01
6.4"	PVI	640x480	V16C6448AC
6.4"	LG-PHILIPS	640x480	LB064V02
6.4"	PVI	640x480	PD064VT2 /VT4 /VT5
6.4"	Sharp	640x480	LQ064V3DG01
7"	AUO	800x480	C070VW02V0
7"	Data image	800x480	FG0700A0DSSWBG01
7"	LG-PHILIPS	800x480 (TFT 24 bits)	LB070WV1
7"	HITACHI	800x480	TX18D57VM2BAA
7"	Samsung	800x480	LMS700KF05
7"	PVI	800x480	PM070WL4
7"	URT	800x480	UMSH-8173MD-1T
7"	CHI HSIN	800x480	LW700AT9309
8"	Sharp	640x480	LQ080V3DG01





## **F. TCP/IP library for DOS real mode**

DSock is a TCP/IP library for DOS real mode, which is used by RSIP. It provides simple C functions for programmer to write Internet applications. IAE also provide Internet examples using DSocket: BOOTP/DHCP, FTP server, SMTP client/server, HTTP server, TELNET server, Talk client/server, etc.

DSock provides a lot of example source code. Programmer can add Internet functions to their project easily and save development time. With a utility "MakeROM", programmer also can make a ROM image to fit their application, those examples can be seen in the following Application systems: Mity-Mite Serial Server, Web Camera Tiny Server and RSIP Serial Server.

DSock is free for All IAE products using M6117D/Vortex86/Vortex86SX/Vortex86DX CPU and ICOP also provide the business version of DSocket for those customers who are using other x86 CPUs.

## G. BIOS Default setting

If the system cannot be booted after BIOS changes are made, Please follow below procedures in order to restore the CMOS as default setting.

- Press “End” Key, when the power on



- Press <Del> to enter the AMI BIOS setup
- Press “F9” to Load Optimized Defaults
- Press “F10” to Save configuration changes and exit setup